



MACONS

◀ **Aggregate Weighing Conveyor :**



Aggregate weighing conveyor has chevron type belt and it is suspended on 4 nos. load cell for accurate weighing system. Weighing conveyor is driven by two gear motors which are directly mounted on both end of drive drum with inbuilt hold back facility. Weighing hopper is made from mild steel suitable to heavy working conditions for long time with mechanical separators.

Aggregate, Cement, Water & Additive Weigher :



Water and Cement hopper mounted on independent modular frame structure and weightment can be done by individual electronic load cell.

Aggregate Storage Bin :



The aggregate storage bins made from mild steel sheet. The aggregate bins have in cross layout. The installation of aggregate storage bins is very user friendly as the construction process and the extension of the pre-assembly reduce the installation time of the plant at site. The aggregate storage bins are broadened to facilitate the loading process by loader. The discharge window of aggregate bins opened through pneumatic cylinders.

Macons is the single source supplier of turnkey Concrete Batching and Mixing plant solutions. With decades of experience in the industry, we have numerous installations of various capacities to our credit. We are renowned for offering you with everything that is needed to run the very heart of your business. In order to produce the highest quality concrete required as well as on-site concrete plants for the construction of large civil projects such as roads, bridges, ports, dams, runways, buildings, tunnels, etc., Macons solutions are designed to confer maximum flexibility by giving your plant the ideal combination of engineered and proven components.

MACONS introduces MAC Model, especially designed for the production of concrete at sites where the quality, flexibility and performance are key features to consider.

The flexibility of this plant begins in the different arrangements available. Four types of mixer models can be selected with a broad range of models: Single Shaft Mixer, Twin Shaft Mixer, PAN type Mixer and Planetary Mixer.

The main advantage of this plant is that it doesn't require large foundations and others civil constructions. The time and money can be saved by easy transportation, assemble and disassemble when plant is shifting from one site to another site.

The constitution of the plant is made in welded construction of steel profiles. The complete structure is shot blasted before the primary coat of paint being implemented. There are two coats of paint applied. Including elements like stairs, balconies, pavements, discharge mouths of the aggregates bins to resist to the attacks of the weather situations.

It's easy to disassemble, transport and assemble again. In one week we assemble your plant in a new site producing concrete, saving you time and money.

Pan Type Mixer :



The Mixer is mainly responsible for good quality concrete, on this way we construct our own energetic mixer. In this mixer all the ingredients are mixed and removed in circles, obtaining a homogenous mixer. It moves and revolves with the arms, absorbing the shocks that are produced through the coupling spring incorporated that regulate the position and slope angle of the paddles, to obtain the work with minimal power consumption. Mixer having replaceable hard liner tiles on shall and bottom. Mixer's top cover can be folded for cleaning of mixer.

◀ **Twin Shaft Mixer :**



The Twin-shaft Mixer offers the most advanced mixing solution, capable of handling from high to zero slump concrete. The twin shaft system mixing consisting two horizontal shafts with arms and paddles moving in counter current; Counter rotating mixing arms and paddle creates a spiral shaped vertical and horizontal mix direction, which ensures to make three dimensional mixing. The twin shaft mixer is the best to make any kind of concrete. The discharge is accomplished by a hydraulic operated gate, which is assembled throughout the length of the mixer vat for fast and complete discharge.

◀ **Control Panel**



- The system combines the power of a PLC and dedicated Batch controllers to provide reliable and accurate control.
- The system can handle up to 4 scales; with 4 Aggregates, upto 3 Cements, Water upto 2 Admixtures, being accurately Batched on 'weight' basis.
- The system is capable of handling multi-scale, multi-ingredient Batching & Mixing operation, with all necessary Interlocking, Toning, Alarm generation, Event-logging, Recipe & Report generation facility.
- Software calibration for all scales with password protection.
- The system has Touch Screen display with compact flash socket to increase memory capacity with 3 Serial communication ports | Ethernet port & | USB port.
- High speed sampling ensures batch to batch accuracy.
- All necessary interlocks are programmed within the system to allow parallel batching and Mixing operations.
- Variety of features incorporated in the system ensures easy and fault free plant operation.

◀ **Rotary Chute Conveyor :**



The rotary chute conveyor has Chevron belt with MS angle heavy duty frame structure. The conveyor has elevated wire rope with integrated plant form railing for easy maintenance. The conveyor is driven by shaft mounted gear reducer with inbuilt hold back facility. The fabricated hopper of 5 mm MS Plate is being supplied with vibrator.

Technical Features

PLANT CAPACITY	UNIT	MAC 30	MAC 45	MAC 60	MAC 75	MAC 90
Compacted Concrete	m ³ /hr	30	45	60	75	90
MIXER SPECIFICATION						
Type of Mixer		PAN / Single Shaft/ Planetary	Single Shaft/ Twin Shaft/ Planetary	Single Shaft/ Twin Shaft/ Planetary	Twin Shaft/ Planetary	Twin Shaft/ Planetary
Mixer Capacity	m ³	0.5	0.75	1	1.5	2
Input / Output Capacity	Lit.	750/500	1250/750	1500/1000	2250/1500	3000/2000
Motor Power	HP	25/30/25	40/40/40	50/50/40	80/80	100/100
AGGREGATE BIN						
No. of Compartment	No.	4	4	4	4	4
Capacity of Each Compartment	m ³	10	10	15	15	20
WEIGHING SYSTEM						
		Electronic - Digital	Electronic - Digital	Electronic - Digital	Electronic - Digital	Electronic - Digital
Aggregate Scale	Kg.	1250	2500	3000	3750	5000
Cement Scale	Kg.	300	600	900	1250	1500
Water Scale	Lit.	150	300	450	600	800
Additive Scale	Kg.	10	10	20	20	20
WATER PUMP						
Connected Power	HP	3	3	5	5	7.5
CEMENT SCREW CONVEYOR						
Diameter	mm	219	219	219	219	273
Connected Power	HP	15	15	15	15	20
AIR COMPRESSOR						
Connected Power	HP	3 HP	3 HP	7.5 HP	7.5 HP	10 HP
CONTROL PANEL						
		Fully Automatic	Fully Automatic	Fully Automatic	Fully Automatic	Fully Automatic
TOTAL CONNECTED LOAD	HP	64.38/69.38 /64.38	77.38/ 79.38/79.38	98.88/ 101.13/100.88	131.13/130.88	158.63/158.38

*Output Production is Considerate with 30 Seconds mixing time

MAC Concrete Batching Mixing Plant available in 30 / 45 / 60 / 75 / 90m³/hr. Capacity.

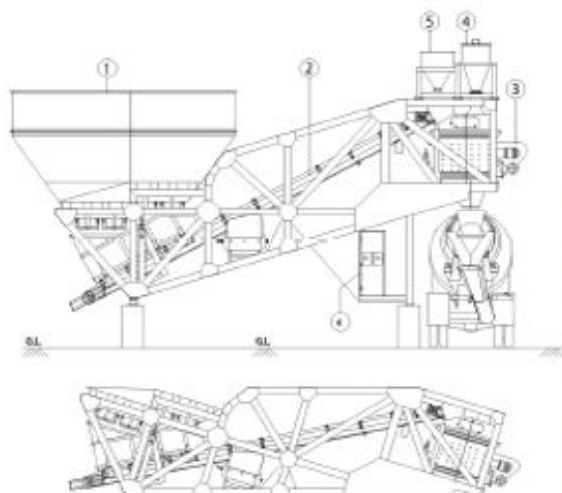

Transportation View

1. BIN HOPPER
2. WEIGHING CONVEYOR
3. TWIN SHAFT/SINGLE SHAFT/ PAN MIXER/PLANETARY MIXER
4. CEMENT HOPPER
5. WATER HOPPER
6. OPERATOR CABIN

Salient features:

- Compact and economically designed.
- Heavy duty structure.
- Longer life of wear & tear parts.
- In-built control cabin not as an optional.
- Especially quick erection & commissioning.
- Inbuilt pipeline of water, additive and pneumatic.
- Tilting type control cabin for easy transportation.
- One operator can run the plant.
- Single Shaft and Planetary Mixer available on request.

Optional:

- Cement / Fly Ash Storage & Conveying System from 20 to 200 MT capacity.
- Microwave Moisture Meter.
- Computer SCADA System with Software.
- Radial Conveyor Belt for Aggregate Feeding.

Design and Specification are subject to change without prior notice.

Transforming construction with Next Age Technology

MAC Concrete Batching Mixing Plant
Available in 30 / 45 / 60 / 75 / 90m³/hr. Capacity.



* Design Patent Applied

MACONS EQUIPMENTS

Plot No. 37/C, Phase-I, G.I.D.C. Estate, Vava, Ahmedabad-382 445 Gujarat-INDIA.
Ph. : 0091 + 79 + 25894558 / 25891510 / 45438746
Fax : 0091 + 79 + 25891097 E-Mail : info@maccons.co.in Website : www.maccons.co.in