

# CASE

CONSTRUCTION

# CASE 851

## LOADER BACKHOE



*We make machines that build the nation*

## Specifications

### Engine

Make	: KOEL
Model	: 4R1040-TA-BS-III
No. Of Cylinders	: 4 Cylinders, Inline
Displacement	: 4160 cc
Type	: 4 Stroke, Turbo charged Water Cooled, Diesel Engine
Gross Power	: 96HP @ 2200 RPM as per ISO 3046
Maximum torque	: 375 Nm @ 1400 RPM
Electrical System	: 12 V DC
Battery	: 130 Ah rating
Alternator	: 65 A rated output

### Transmission

Single stage hydrokinetic type torque converter Shuttle ranger with 4 speed synchromesh gearbox.

Travel Speeds with 16.9X28 rear tyres  
Gear Forward/Reverse

I	4.8/5.8
II	7.8/9.3
III	16.6/Not Recommended
IV	29.7/Not Recommended

### Hydraulic System

Gear Pump Max. output @ 2200 RPM	: 151 lpm
System Pressure	: 210 Bar

### Axles & Brakes

Front Axle	: Heavy Duty oscillating 20 Deg type Steering axle
Rear Axle	: Rigid With inboard planetary drives
Wheel Base	: 2200 mm (2WD) 2175 mm (4WD)
Brakes	: Oil immersed wet disc brakes on rear wheels hydraulically actuated.

### Service refill capacities

Hydraulic system capacity(Main)	: 137 Litres
Fuel Tank	: 127 Litres
Engine Coolant Water	: 20 Litres
Engine Oil	: 9.5 Litres
Transmission	: 16 Litres
Axle	: 22 Litres

### Steering

Steering	: Hydraulic actuation with independent Hydraulic Circuit
Steering Gear Pump Max. output @ 2200 RPM	: 22 lpm
Turning Radius with brake	: 3217mm (Outside Tyre)
Turning Radius without brake	: 4488mm (Outside Tyre)

*Extendhoe - optional*



Buckets	Capacity (SAE L)	Width (mm)	Wt. (kg)
Loader HD	630	1532	230
Loader HD	760	2277	308
Loader GP	900	2277	365
Loader GP	1000	2277	400
Loader coal handling	1200	2277	435
Loader Garbage handling (without teeth)	1500	2277	480
Bull Clam	1000	2300	560
Trenching	80	305	117
Trenching	120	457	141
Trenching	180	610	161
Trenching	243	762	184
Trapezoidal	300	305	200
Ditch Cleaning (without teeth)	300	895	205



### Optional Equipment

- ★ 4-Wheel Drive (4x4 Traction)
- ★ Rockbreaker
- ★ Lifting arrangement
- ★ Extending type dipper
- ★ Bottom dump bucket
- ★ Ripper Tooth
- ★ Backfill blade
- ★ Heavy duty tyres -14X25-20 PR
- ★ Dozer blade
- ★ Lime Stone scraper
- ★ Wood log grapple



# CASE 851 LOADER BACKHOE SPECIFICATION SHEET

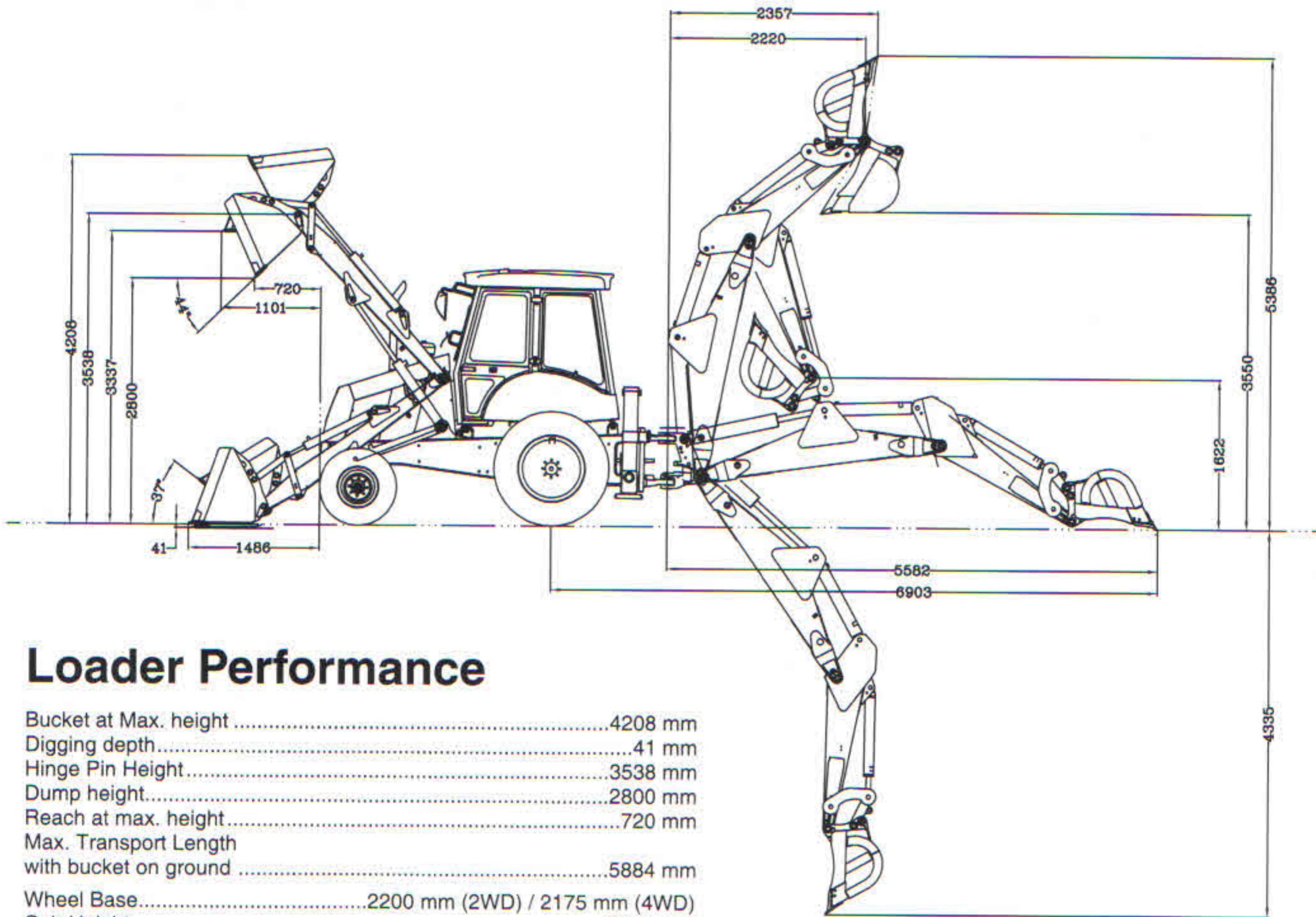

## Loader Performance

Bucket at Max. height .....	4208 mm
Digging depth.....	41 mm
Hinge Pin Height.....	3538 mm
Dump height.....	2800 mm
Reach at max. height.....	720 mm
Max. Transport Length with bucket on ground .....	5884 mm
Wheel Base.....	2200 mm (2WD) / 2175 mm (4WD)
Cab Height.....	2908 mm
Transport height .....	3887 mm
Transport width .....	2320 mm
Breakout force.....	6314 kg
Lifting capacity at top height.....	3425 kg

### LOADER BUCKET

TYPE.....	
CAPACITY .....	1 cu.m.
WIDTH .....	2215 mm
WEIGHT WITH TEETH.....	440 kg

Operating weight (with 1000 L loader bucket  
and 240 L B/H bucket, 80 Kg operator and  
full fuel tank .....

7500 Kg			
Heap capacity SAE J-296 Litres .....	Litres.....	Width .....	Weight
	80 .....	305 .....	117
	120.....	457 .....	141
	175.....	610 .....	161
	240.....	762 .....	185

- All dimensions in mm

For further information, contact:



### CASE NEW HOLLAND CONSTRUCTION EQUIPMENT (INDIA) PRIVATE LIMITED

First Floor, North Block-II, Gate No.1, Saki - Vihar Road,  
L&T Campus, Powai West, Mumbai - 400 072, India  
Phone : +91 - 22 - 6705 1279 / 1471, Fax: +91 - 22 - 6705 1829  
Email : CASEIndia@cnh.com, www.casece.com

## Backhoe Performance

BACKHOE TYPE	2 WD VERSION STANDARD
Loading Reach at max. height .....	2357 mm
Bucket rotation angle .....	
Speed Hole.....	204 Deg
Power hole .....	160 mm
Max. cutting height.....	5386 mm
Max. dump height .....	3550 mm
Digging depth (SAE) .....	4270 mm
Max. Digging depth .....	4335 mm
Reach from swing centre .....	5582 mm
Reach from rear axle .....	6903 mm
Width at stabilizers (work) .....	2256 mm
Width at stabilizers (transport) .....	2320 mm
Breakout force .....	
Bucket cylinder .....	5630 Kg
Dipper cylinder.....	4120 Kg
Lifting capacity inside dipper stick reach (ISO).....	2080 Kg
Lifting capacity with dipper stick at 3.6 m from ground level (ISO) .....	2100 Kg

Authorised Dealer

Specification subject to change without notice due to product upgradation